

MANUAL

INSTALLATION AND OPERATION

Rotary Compressors RK, RG and HG

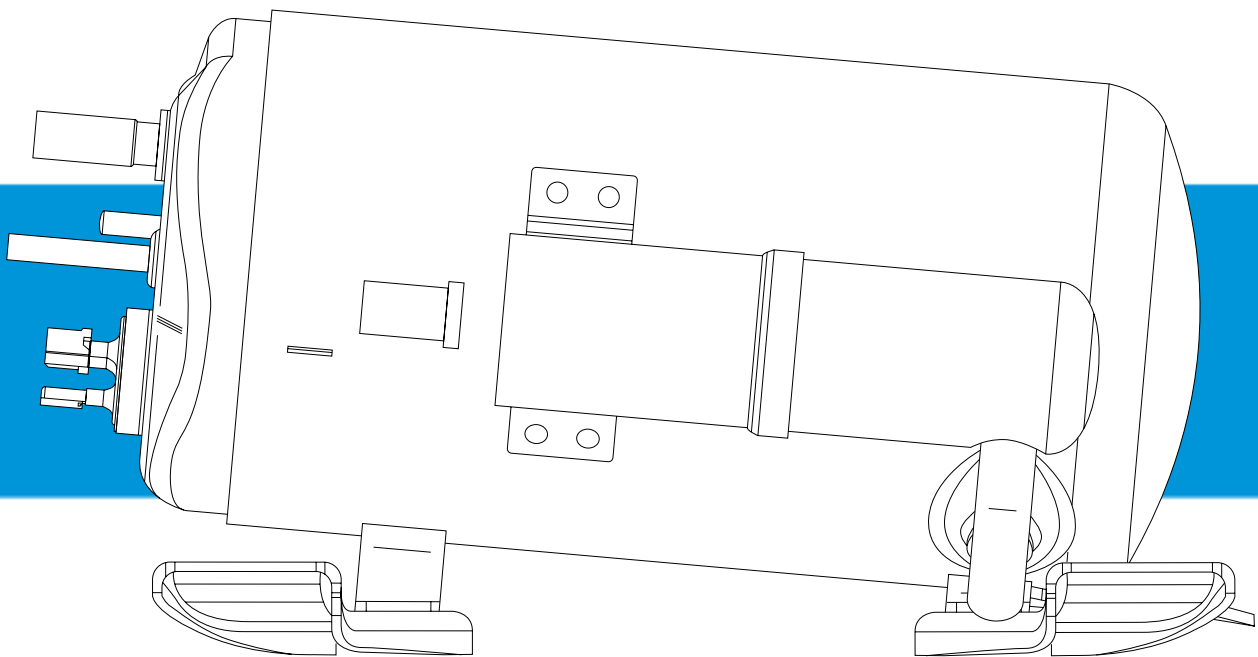

1 General Information 5

1.1	The working principle of the Rotary Compressor	5
1.2	Range	6
1.3	Performance	7
1.4	Voltage and range of operation	7
1.4.1	Single phase	7
1.4.2	Three phase	7
1.5	Dimensions and connections	8
1.6	Mountings	8
1.7	Oil type	8

2 Operating Range 9

2.1	Operating envelope	9
2.2	Operating compression ratio	9
2.3	Operating pressure differential	9

3 Temperature Criteria 10

3.1	Ambient temperature	10
3.2	Discharge temperature	10
3.3	Motor temperature	10
3.4	Return gas temperature	10

4 General Recommendations 11

4.1	System requirements	11
4.2	Pipework design	11
4.2.1	Pipework design advice/guidance	11
4.2.2	Connections	14
4.2.3	Flexible connections	14
4.2.4	Velocity within pipework and heat exchangers	14
4.2.5	Capillaries	16
4.3	Refrigerant charge	21
4.3.1	Advice for installers	21
4.3.2	Refrigerant charge	21
4.4	Starting	21
4.4.1	Frequency of starts	21
4.4.2	Start-up pressure	21

4 General Recommendations (continued)

4.5	Liquid return whilst operating	22
4.6	Liquid migration during prolonged shutdown	22
4.6.1	Band heaters	22
4.6.2	Non-return valves	22
4.7	Purging refrigerant from the system	22

5 Security 23

5.1	Pressure	23
5.2	Electrical	23
5.3	Declaration of incorporation	23

6 Appendices 25

6.1	Documents	25
6.2	Contacts	25

Tecumseh Europe with its long experience of compressor development has introduced a range of rotary compressors for air conditioning and commercial refrigeration.

This operating manual has been designed to help you correctly install this compressor range in your applications.

1 General Information

1.1 The working principle of the Rotary Compressor

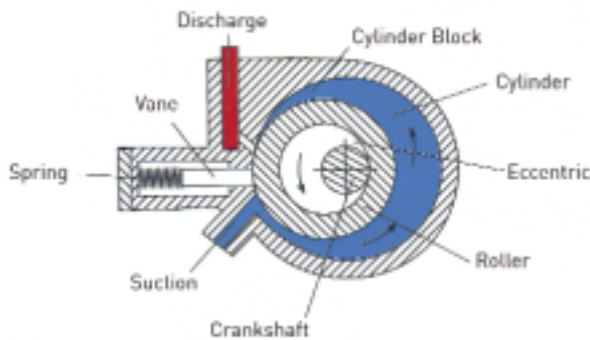

1 | Names of the different pieces

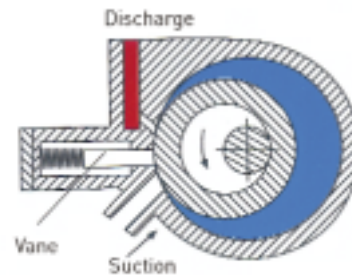

2 | End of suction and the start of compression

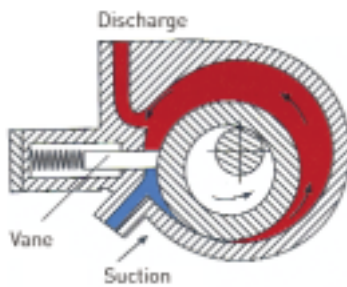

3 | Start of compression and suction

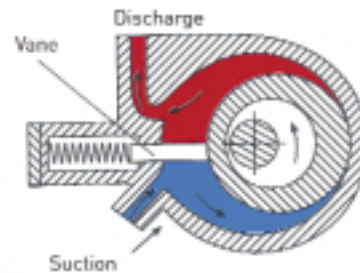

4 | Compression and suction

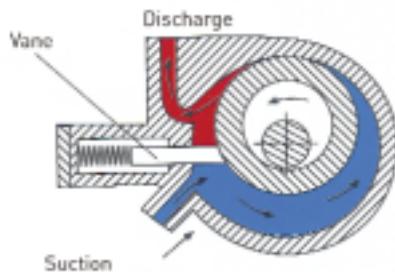



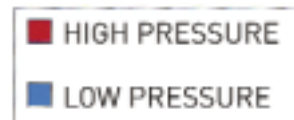

5 | Compressed gas exit



Rotary compressors are 'high pressure shell' type compressors. The suction on these compressors is taken directly into the compression chamber. Gas compressed in the compression chamber is discharged into the compressor casing. It should be noted that from a cold start-up, high pressure shell type compressors take longer to reach their normal operating pressure in the compressor shell. This is partly due to the larger volume of the compressor casing and partly as a result of refrigerant being trapped in the oil. Any refrigerant in the oil has to completely evaporate before condensing pressure can reach its operating level.

Sucking bottle

Excessive refrigerant, oil or impurity in the suction chamber of the compressor can result in mechanical damage. As a result, all our compressors are fitted with an accumulator equipped with a filter.

	AIR CONDITIONING		COMMERCIAL
VERTICAL	 <p>RG range, accumulator capacity → 100 cm³</p>	 <p>RK range, accumulator capacity → 160 cm³</p>	 <p>RG range, accumulator capacity → 680 cm³</p>
HORIZONTAL	 <p>HG range, accumulator capacity → 70 cm³</p>		 <p>HG range, accumulator capacity → 405 cm³</p>

Please note that overcharging with refrigerant is one of the major causes of damage to the compressor. It is important to check the amount of refrigerant being used is correct.

1.2 Range

	VERTICAL		HORIZONTAL
Application	RG	RK	HG
Air Conditioning or Heat Pump	R22	R22	R22
		R134a	
	R407C	R407C	R407C
Commercial Refrigeration Low Back Pressure	R404A		R404A
Commercial Refrigeration High Back Pressure	R134a		R134a
	R404A		R404A

1.3 Performance

Please refer to the Technical Data Sheets for information on compressor performance.

1.4 Voltage and range of operation

The voltage range of the rotary compressors corresponds to the standard ranges defined by Tecumseh Europe. See the General Catalogue for more information.

Start-up should never be carried out when the electrical cover has been removed.

1.4.1 Single phase

Single phase compressor motors are two pole asynchronous and they are designed to be used with different types of starting method depending on the application (PSC, CSR, CSIR).

Please ensure the starting mode follows that specified on the Technical Data Sheet for each product.

We recommend the use of components specified by Tecumseh Europe.

For wiring instructions, follow the diagram supplied with the compressor.

Ensure that the start and run windings are connected correctly otherwise damage to the motor will result (see label below).



1.4.1.1 Motor protection

The motor is protected by an externally mounted temperature and current sensitive overload. It is imperative that the overload protector is connected as it cuts off the power supply to the compressor if a fault occurs. For wiring instructions, follow the wiring diagram supplied with the compressor.

1.4.2 Three phase

All rotary compressors which have a model number beginning with a letter 'T' are equipped with a three phase motor.

Three phase motors are wired in star, and the resistance measured between two terminals corresponds to the resistance of that coil.

Ensure that each compressor conforms to the information given on the Technical Data Sheet.

We recommend the use of components specified by Tecumseh Europe.

For wiring instructions, follow the diagram supplied with the compressor.

1.4.2.1 Phase control

Care should be taken when connecting three phase rotary compressors to ensure that the direction of rotation is correct as rotation occurs in one direction only.

ATTENTION: If the rotational direction is incorrect, the compressor will not refrigerate and the life of the product will be reduced. However, a short test period will not cause damage.

To ensure correct rotation we recommend the use of our phase detector reference number 8 535 136, which is listed in our Spare Parts and Accessories Catalogue.

1.4.2.2 Protection of the motor

The motor is protected from overheating by an external overload protector which must be connected. This device has a single contact and cannot be wired into the three phase electrical supply of the compressor (a three phase motor can only operate with a minimum of 2 active phases). The protector should therefore be wired into the control circuit of the compressor so that it cuts the power supply if a fault occurs. For wiring instructions, see the electrical diagram supplied with the compressor.

For further information on protecting the compressor against high current, please contact the technical application department at Tecumseh Europe.

1.5 Dimensions and connections

The dimensions and the position of the connections are given in our Technical Data Sheets.
The compressors can tolerate an angle of tilt of +/- 7° for vertical models and +5°/0° for horizontal versions.

1.6 Mountings

We recommend the fitting of anti-vibration mounting feet as specified by Tecumseh Europe (see table below).

Natural or synthetic rubber products bearing weight for long periods tend to lose their shape. This occurs more quickly when they are subject to an excessive loading and/or heat. Anti-vibration mounting feet should be regularly checked to ensure optimal operation of the installation and replaced where necessary to ensure the sound level does not increase.

RANGE	STANDARD MOUNTING	STANDARD PLAY	MAXIMUM TORQUE SETTINGS	
RG	3 feet	8 682 021	13.8 Nm to 17.9 Nm (10 to 13 ft.lbs)	
HG	4 feet	8 682 025		
RK	3 feet	8 682 021		

The length of the AV mount insert used allows the mounts to function correctly and prevents overtightening.

Specific mounts can be supplied for applications where greater vibration reduction is required. For further information, contact your local representative.

1.7 Oil type

APPLICATION	REFRIGERANT	OIL
Air Conditioning or Heat Pump	R22	Alkyl Benzene
	R407C	Short pipe run* (<3,6m): Alkyl Benzene Long pipe run* (≥3,6m): PVE
	R134a	Polyolester
Commercial Refrigeration Low Back Pressure	R404A	Polyvinyl ether
Commercial Refrigeration High Back Pressure	R404A	Polyvinyl ether
	R134a	Polyolester

* Short or long pipe run: Distance between the condenser and the evaporator.

The design of the rotary compressors is such that an oil change or the addition of oil should not be carried out.

We strongly advise against adding oil to the refrigeration system whether the pipework is long or short.

2 Operating Range

2.1 Operating envelope

The operating envelope is in accordance with EN 12 900, with a superheat of 10K for air conditioning and heat pump applications, and return gas of 20°C for all other applications (See diagrams in the appendices).

For more information please refer to the Technical Data Sheet for each product.

2.2 Operating compression ratio

The operating compression ratio is the ratio between absolute condensing and evaporating pressures. It is essential to adhere to the maximum values listed in the following table.

Exceeding these values will reduce the working life of the compressor or even cause a breakdown.

APPLICATION	REFRIGERANT	COMPRESSION RATIO
Air Conditioning or Heat Pump	R22	7
	R134a	15.8
	R407C	7
Commercial Refrigeration Low Back Pressure	R404A	22
Commercial Refrigeration High Back Pressure	R404A	8
	R134a	15.8

2.3 Operating pressure differential

The operating pressure differential corresponds to the difference between absolute discharge and suction pressure. Maximum levels are listed in the table below. Exceeding these values will reduce the working life of the compressor or even cause a breakdown.

APPLICATION	REFRIGERANT	PRESSURE DIFFERENTIAL (BAR)
Air Conditioning or Heat Pump	R22	22
	R407C	23.5
	R134a	23
Commercial Refrigeration Low Back Pressure	R404A	27.1
Commercial Refrigeration High Back Pressure	R404A	25
	R134a	23

3 Temperature Criteria

3.1 Ambient temperature

The compressors have been designed to operate in the following ambient temperatures (with forced air cooling).

	AMBIENT TEMPERATURE
Air Conditioning or Heat Pump	46°C
Commercial Refrigeration	43°C

Comment:

For air conditioning applications operating in high ambient conditions, see our tropical range. These products use R-134a and have an evaporating temperature range of -10°C to +30°C, and a condensing temperature range of +30°C to +80°C for a temperature of 55°C.

3.2 Discharge temperature

The maximum discharge temperature is 127°C. This temperature can be measured by soldering a thermocouple onto the discharge pipe 5 cm from the compressor and insulating it for 10 cm.

3.3 Motor temperature

All our single phase rotary compressors are supplied with an external overload protector. The maximum permitted operating temperature is 130°C which is measured by the resistance variation method.

Resistance variation method: Leave the application switched off in a constant temperature (temperature t_1) for at least 8 hours. Measure the motor winding resistance R_1 at this temperature t_1 . With three phase motors, measure the resistance between 2 electrical supply terminals to the compressor.

Run the application in the most difficult conditions foreseeable, switch off the machine and immediately measure the new motor winding resistance (R_2). With three phase motors, measure the resistance between the 2 terminals used before.

The new temperature t_2 can easily be calculated using the following equation:

$$t_2 = \frac{R_2}{R_1} * (t_1 + 234.5) - 234.5$$

t_1 & t_2 are given in degrees Celsius.

3.4 Return gas temperature

A minimum superheat of 10K is necessary between the evaporating temperature and suction temperature at the inlet of the compressor. However, it is necessary to control superheat to prevent exceeding the maximum return gas temperature for the compressor and the compressor motor (see sections 3.2 and 3.3).

4.1 System requirements

Rotary compressors are 'direct suction'. The suction gas enters directly into the compression chamber. The suction accumulator incorporates a filter to protect the compressor against dirt and debris entering the pump.

It is essential that all necessary precautions are taken to ensure the system is kept clean during installation and service e.g. purge the system with Nitrogen whilst brazing.

4.2 Pipework design

The function of the pipework is to allow the refrigerant to circulate through the system components in such a way as to provide optimum operating conditions, i.e.:

- Limited pressure drop,
- Velocity is sufficient to entrain the oil,
- Ensure that the compressor is protected against the return of liquid refrigerant particularly when the installation is switched off.
- A full head of liquid refrigerant at the expansion device.

As in all refrigerating systems using hermetic compressors, some of the oil from the compressor circulating within the system is entrained with the refrigerant. The amount varies according to the operating conditions of the installation. No additional components e.g. oil separator, oil coolers etc. are required to assist with oil control in rotary compressor systems.

However, it is essential to ensure the oil return to the compressor otherwise its working life may be shortened and its performance affected.

All pipework in the refrigerating system must be designed to return oil to the compressor. The design must prevent oil being trapped in the pipework, the system components and the heat exchangers. Refrigeration best practice must be respected.

Due to the difficulty of controlling the return of oil in a multi-evaporator system, we advise that the rotary compressors should only be used in a single circuit system.

4.2.1 Pipework design advice/guidance

4.2.1.1 Suction pipework

Suction pipework returns refrigerant gas to the compressor from the evaporator. The main factors to consider are:

- A partial refrigerant charge caused by a leak or incomplete charging will cause a reduction in compressor capacity due to the lower suction pressure,
- Reduce the return gas superheat in order to limit the discharge temperature,
- Ensure that the refrigerant velocity is sufficient to return the oil to the compressor which has a small oil charge,
- Prevent refrigerant entering the compressor during either the running or off cycles. The possibility of any liquid slugs of oil entering the compressor during the running must also be prevented.

In practice, suction lines are generally designed for pressure drops of no more than 1°C saturated temperature.

1 - If the compressor is located higher than the evaporator, the oil return to the compressor must be guaranteed. Oil traps at the beginning of the suction risers must be used and the pipe line velocity must be sufficient to ensure oil flow in suction risers. A smaller size oil trap could be used before the suction riser.

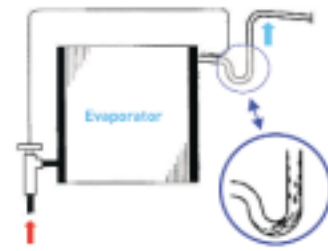

Riser

2 - When the compressor is on the same level or lower than the evaporator, we recommend that swan neck suction line is used where the top of the swan neck is above the evaporator, whether the suction exit of the evaporator is at the top or bottom.

This is to prevent the gravitational flow of refrigerant to the compressor during the off cycle.

On the other hand, an oil trap should not be used close to the suction of the compressor to prevent oil/refrigerant slugs (or a mixture of both) reaching the compressor.

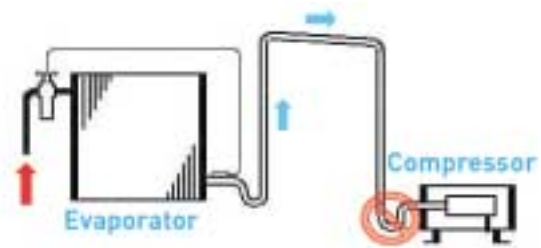

Suction pipework

3 - The above design can be simplified by using a “pump down” control system.

This system requires the installation of a solenoid valve (LLSV) prior to the expansion device (EXV). The compressor is controlled by a low pressure switch. Before pump down can occur, the solenoid valve must be closed in order to pump out the evaporator and transfer the refrigerant to the high pressure side. As the low pressure in the suction reaches the cut off point of the low pressure switch, the pressure switch stops the compressor.

Liquid cannot therefore accumulate at the suction of the compressor.

The suction piping then drops directly towards the compressor.

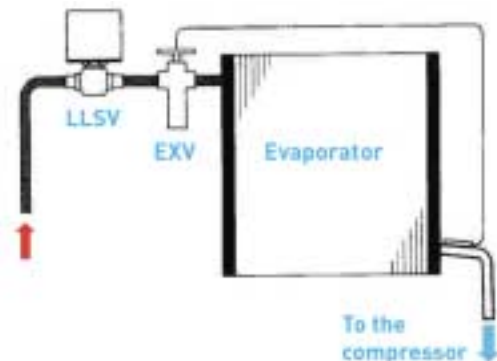

Pump down

4.2.1.1.1 Discharge pipework

The discharge pipework carries refrigerant gas compressed by the compressor to the condenser. The main factors to consider are:

- Minimum pressure drop,
- The velocity is sufficient to take the oil to the condenser even when there is only a partial charge,
- Ensure that liquid (oil, refrigerant or both) does not migrate towards the compressor during the off cycle.

In practice, discharge piping can be designed for a pressure drop of up to 1°C at saturation temperature. Pressure drop in the discharge pipework can cause a slight reduction in capacity as the compressor has to operate at a discharge pressure higher than the condensing pressure.

If the installation is such that the compressor is the coldest part of the system (i.e. has the lowest temperature), a non-return valve must be fitted close to the condenser to isolate the condenser from the compressor.

The valve is also an advantage during start-up where a large pressure differential may occur. (see § 4.4.2)

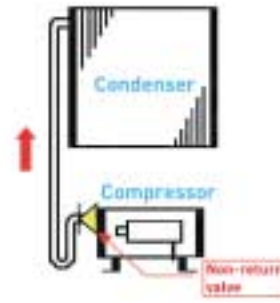

Discharge pipework

4.2.1.1.2 Liquid pipework

The liquid line supplies liquid refrigerant to the expansion device from the condenser/receiver. When sizing a liquid line the main factors to consider are:

- The re-heating of the duct,
- Minimum pressure drop.

In this part of the system, because the oil and refrigerant are miscible, oil flow does not present any particular problems. However, attention must be paid to ensuring there is a constant supply of liquid to the expansion device. Under no circumstances must the refrigerant be heated and pressure changes in the pipework must be prevented.

If liquid refrigerant experiences a pressure below its saturation pressure, it will vaporize within the pipework.

To ensure the expansion device functions correctly, the pressure of the liquid reaching it must be sufficiently high, and preferably, slightly subcooled. It is essential to restrict the pressure drop in the pipework for the following reasons:

- To prevent a reduction in the mass flow through the expansion device,
- To prevent partial vaporization of the liquid refrigerant prior to the expansion device (pressure drop higher than subcooling).

The components fitted to the liquid line such as the filter drier, solenoid valve, liquid line sight glass also cause varying pressure drops.

The pressure drop in this pipework must not exceed 0.5°C.

4.2.1.1.3 Positioning of accessories on the liquid line

The diagrams below show the normal position of accessories on the liquid line.

The filter drier must be positioned next to the expansion device to prevent clogging by impurities. It should be installed in a vertical position with the outlet downwards to ensure constant liquid supply to the expansion device.

The liquid sight glass should be positioned between the drier and the expansion device in order to indicate that:

- Liquid / vapour is present,
- The level of residual humidity.

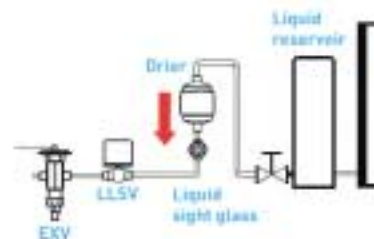

Liquid line - position of accessories

4.2.2 Connections

The rotary compressors have copper connections. The positioning of connections is given in the Technical Data Sheets. Please note the following:

- Brazing should be carried out using an inert gas (Nitrogen).
- Protect paintwork while brazing by covering the accumulator and compressor with a damp cloth. Do not allow the flame to come in contact with paintwork.
- Brazing of the connections must comply with the recommendations of the Standard NF EN 378-2.
- Carry out pipe cutting and bending operations carefully in order to prevent dust and swarf contaminating the system.

Care should be taken to ensure that flux does not contaminate the system.

4.2.3 Flexible connections

Rotary compressors do not have internal mounting springs, in contrast to the majority of hermetic compressors. The internal design and external mountings are designed to reduce vibration. However, some vibration is transmitted to the suction and discharge pipework. We therefore recommend using flexible connections to prevent vibration being transmitted to the rest of the installation.

We recommend using annealed copper pipe rather than hard drawn.

A suggested design of flexible connections for this range of compressors and their applications is shown in the diagrams in the Appendices (see p. 25).

The general design of the pipework can be adjusted according to your equipment. The recommended suction loop of 3/8 inch and 1/4 inch discharge should be adhered to.

Great care should be taken when designing the system and correct refrigeration practices must be followed to ensure the oil return to the compressor.

4.2.4 Velocity within pipework and heat exchangers

To ensure correct running of the installation and to assure the working life of the compressor, it is recommended that pipework be calculated using the velocities shown in the table below.

Connections	SUCTION		DISCHARGE		LIQUID	
	Minimum	Maximum	Minimum	Maximum	Minimum	Maximum
Anti-vibration loops		25 m/s		25 m/s		
Pipework	4 m/s	15 m/s	4 m/s	15 m/s	0.3 m/s	1 m/s
Evaporator	3 m/s	8 m/s				
Condenser			3 m/s	10 m/s		

Anti-vibration loops are used to provide a very flexible pipework system which absorbs vibration. The velocity in the AV loops should not exceed that stated in the table.

A minimum velocity of 8 m/s is necessary in any vertical risers, suction or discharge to ensure adequate oil return to the compressor.

The velocity within the heat exchangers should not drop below 3 m/s to guarantee oil return.

The table page 21 lists the velocities for different internal diameter pipework and compressor models. The choice of pipework should therefore be made for a particular model of compressor and specified type of connection (suction, discharge or liquid pipework) in accordance with the velocity ranges recommended in the above table.

In the case of the heat exchangers, the number of circuits can be defined on the basis of the refrigerant velocity circulating in the tubes, taking as reference the value calculated at the suction for the evaporator and at the discharge for the condenser.

Refrigerant velocity in the suction pipework (in m/s)

	CAPILLARY - INTERNAL DIAMETER (mm)															
	Suction						Discharge					Liquid				
	6	8	10	12	14	16	3	5	7	9	11	3	5	7	9	11
HG/RG2426Z	13.7	7.7	4.9	3.4	2.5	1.9	6.7	2.4	1.2	0.7	0.5	0.61	0.22	0.11	0.07	0.05
HG/RG2432Z	16.2	9.1	5.8	4.1	3.0	2.3	7.9	2.8	1.5	0.9	0.6	0.73	0.26	0.13	0.08	0.05
HG/RG2436Z	17.9	10.1	6.4	4.5	3.3	2.5	8.7	3.1	1.6	1.0	0.6	0.80	0.29	0.15	0.09	0.06
HG/RG2446Z	23.3	13.1	8.4	5.8	4.3	3.3	11.3	4.1	2.1	1.3	0.8	1.04	0.38	0.19	0.12	0.08
HG/RG4467Z	14.6	8.2	5.2	3.6	2.7	2.0	18.5	6.6	3.4	2.1	1.4	1.70	0.61	0.31	0.19	0.13
HG/RG4480Z	17.4	9.8	6.3	4.3	3.2	2.4	22.1	7.9	4.1	2.5	1.6	2.03	0.73	0.37	0.23	0.15
HG/RG4492Z	19.9	11.2	7.2	5.0	3.7	2.8	25.3	9.1	4.6	2.8	1.9	2.32	0.84	0.43	0.26	0.17
HG/RG4512Z	24.7	13.9	8.9	6.2	4.5	3.5	31.3	11.3	5.7	3.5	2.3	2.88	1.04	0.53	0.32	0.21
HG/RG4445Y	14.2	8.0	5.1	3.6	2.6	2.0	16.0	5.7	2.9	1.8	1.2	0.66	0.24	0.12	0.07	0.05
HG/RG4450Y	17.2	9.7	6.2	4.3	3.2	2.4	19.3	7.0	3.5	2.1	1.4	0.80	0.29	0.15	0.09	0.06
HG/RG4460Y	19.2	10.8	6.9	4.8	3.5	2.7	21.6	7.8	4.0	2.4	1.6	0.90	0.32	0.16	0.10	0.07
HG/RH4476Y	25.0	14.1	9.0	6.2	4.6	3.5	28.1	10.1	5.2	3.1	2.1	1.17	0.42	0.21	0.13	0.09
RK5450Y	18.1	10.2	6.5	4.5	3.3	2.6	21.2	7.6	3.9	2.4	1.6	1.05	0.38	0.19	0.12	0.08
RK5480Y	29.8	16.7	10.7	7.4	5.5	4.2	34.7	12.5	6.4	3.9	2.6	1.72	0.62	0.32	0.19	0.13
RK5512Y	38.3	21.6	13.8	9.6	7.0	5.4	44.8	16.1	8.2	5.0	3.3	2.21	0.80	0.41	0.25	0.16
RGA5480C	17.6	9.9	6.3	4.4	3.2	2.5	21.5	7.7	3.9	2.4	1.6	1.53	0.55	0.28	0.17	0.11
RGA5492C	19.8	11.1	7.1	5.0	3.6	2.8	24.2	8.7	4.4	2.7	1.8	1.72	0.62	0.32	0.19	0.13
RGA5510C	22.3	12.5	8.0	5.6	4.1	3.1	27.3	9.8	5.0	3.0	2.0	1.94	0.70	0.36	0.22	0.14
RGA5512C	24.5	13.8	8.8	6.1	4.5	3.5	30.0	10.8	5.5	3.3	2.2	2.13	0.77	0.39	0.24	0.16
RK5480C	17.7	10.0	6.4	4.4	3.3	2.5	21.7	7.8	4.0	2.4	1.6	1.54	0.56	0.28	0.17	0.11
RK5490C	19.2	10.8	6.9	4.8	3.5	2.7	23.5	8.4	4.3	2.6	1.7	1.67	0.60	0.31	0.19	0.12
RK5510C	23.0	12.9	8.3	5.7	4.2	3.2	28.1	10.1	5.2	3.1	2.1	2.00	0.72	0.37	0.22	0.15
RK5512C	24.5	13.8	8.8	6.1	4.5	3.5	30.0	10.8	5.5	3.3	2.2	2.13	0.77	0.39	0.24	0.16
RK5513C	27.9	15.7	10.0	7.0	5.1	3.9	34.1	12.3	6.3	3.8	2.5	2.43	0.87	0.45	0.27	0.18
RK5515C	34.0	19.1	12.2	8.5	6.2	4.8	41.5	14.9	7.6	4.6	3.1	2.96	1.06	0.54	0.33	0.22
RK5518C	38.9	21.9	14.0	9.7	7.1	5.5	47.6	17.1	8.7	5.3	3.5	3.39	1.22	0.62	0.38	0.25
RGA5480E	17.7	10.0	6.4	4.4	3.3	2.5	24.0	8.6	4.4	2.7	1.8	1.54	0.55	0.28	0.17	0.11
RGA5492E	19.8	11.1	7.1	4.9	3.6	2.8	26.7	9.6	4.9	3.0	2.0	1.72	0.62	0.32	0.19	0.13
RGA5510E	21.0	11.8	7.6	5.3	3.9	3.0	28.4	10.2	5.2	3.2	2.1	1.83	0.66	0.34	0.20	0.14
RGA5512E	24.9	14.0	9.0	6.2	4.6	3.5	33.7	12.1	6.2	3.7	2.5	2.16	0.78	0.40	0.24	0.16
RK5480E	17.3	9.7	6.2	4.3	3.2	2.4	23.4	8.4	4.3	2.6	1.7	1.50	0.54	0.28	0.17	0.11
RK5490E	19.9	11.2	7.2	5.0	3.7	2.8	26.8	9.7	4.9	3.0	2.0	1.72	0.62	0.32	0.19	0.13
RK5510E	22.6	12.7	8.1	5.7	4.2	3.2	30.6	11.0	5.6	3.4	2.3	1.96	0.71	0.36	0.22	0.15
RK5512E	25.0	14.1	9.0	6.2	4.6	3.5	33.7	12.1	6.2	3.7	2.5	2.17	0.78	0.40	0.24	0.16
RK5513E	27.9	15.7	10.0	7.0	5.1	3.9	37.6	13.5	6.9	4.2	2.8	2.42	0.87	0.44	0.27	0.18
RK5515E	32.4	18.2	11.7	8.1	6.0	4.6	43.8	15.8	8.0	4.9	3.3	2.81	1.01	0.52	0.31	0.21
RK5518E	37.9	21.3	13.6	9.5	7.0	5.3	51.1	18.4	9.4	5.7	3.8	3.29	1.18	0.60	0.37	0.24

4.2.5 Capillaries

Capillaries are currently used as expansion devices in small refrigeration installations as they are:

- Easy to use,
- Inexpensive,
- Reliable: there are no moving parts,
- Permits the use of low starting torque compressors, provided pressure equalization can be achieved during the off cycle.

However, selecting the appropriate capillary always requires great care and some experimentation may be necessary if one does not have a thorough knowledge of the behaviour of the different parts of the system and the factors which affect the way they function.

Capillaries must allow the correct amount of refrigerant to flow to the evaporator. The main factors determining flow are:

- Evaporating temperature,
- Condensing temperature,
- The temperature of subcooled liquid entering the capillary.

As these parameters vary according to the application, it is very difficult to determine a capillary which gives optimum performance across the range of operation when either running continuously or cycling, at start-up or during pull down. The selection of a capillary will therefore always be the result of a compromise between these different criteria.

It is wrong to think that the selection of a capillary is based purely on the use of a mathematical formula. As an example, a variation of 10K in condensing temperature results in approximately a 5K variation in evaporating temperature.

If the diameter of your capillary is not listed in the tables (p. 18-19-20), the length can be calculated from the nearest diameter provided that it does not exceed the diameter of your capillary by +/-0.2 mm (0.008 inch).

$L1 = L2 \otimes \left(\frac{D1}{D2} \right)^{4.5}$, where D1 is the available diameter and L1 the new length to be calculated.

D2 and L2 are respectively the recommended diameter and length listed in the tables (p. 18-19-20).

The tables give the recommended internal diameters and capillary length.

Note that a laboratory test with a longer capillary may give better results. However, if these parameters were to be generally applied, problems would occur in a number of applications. A variation of 1/10 th in the diameter will affect the length of the capillary.

It is essential to use capillary line specified as 'calibrated for refrigeration' when selecting your capillaries.

Capillary lengths from 1.5 m up to 3 m are considered to provide the best performance.

A capillary tube that is too short increases the risk of hunting. A capillary tube that is too long will not allow the operating conditions to change and will require longer for the system to equalize. This will be problematic in systems where the cycle time is short. In addition, the pull down time will be longer.

It is important to highlight the effect the charge of refrigerant has on the operation of systems with capillary tube. A different charge weight of refrigerant is required for each capillary. It is therefore essential to test the capillary / refrigerant charge combination when carrying out validation tests. If different capillaries are tested with the same charge, the results will differ.

- Insufficient charge results in low evaporation temperature, causing a reduction in cooling and only partial use of the heat exchange surface of the evaporator,
- Excessive charge can cause excessive discharge pressure, overloading of the compressor, liquid slugging to the compressor as well as reducing the capacity of the evaporator.

The use of a liquid / suction line heat exchanger made from the capillary tube and suction pipework will produce:

- A 5% increase in performance,
- Greater reliability by reducing the likelihood of liquid / wet gas slugs.

It is even more effective when the contact, i.e. the heat exchange surface, is as long as possible or when more than one capillary is used (2 capillaries are preferable to 1).

The diagrams below show the different types of heat exchange which can be used.

Coaxial



Capillary fixed onto the suction line by aluminium tape

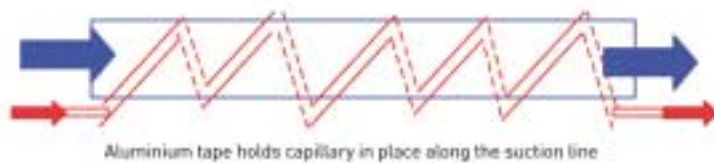

Capillary soldered to the suction line

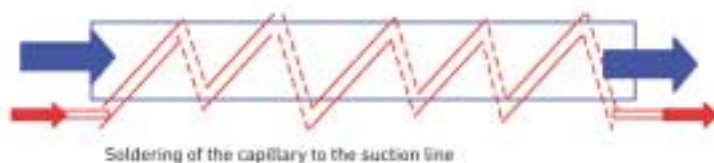

4.2.5.1 Testing a capillary

In the case of mass produced equipment, testing may be necessary due to slight manufacturing variations in the internal diameter, roundness and internal finish of the capillary.

Select a capillary of the appropriate dimensions for the installation using the tables and test it in the refrigeration system. It is then easy to obtain identical capillaries for other installations of the same type.

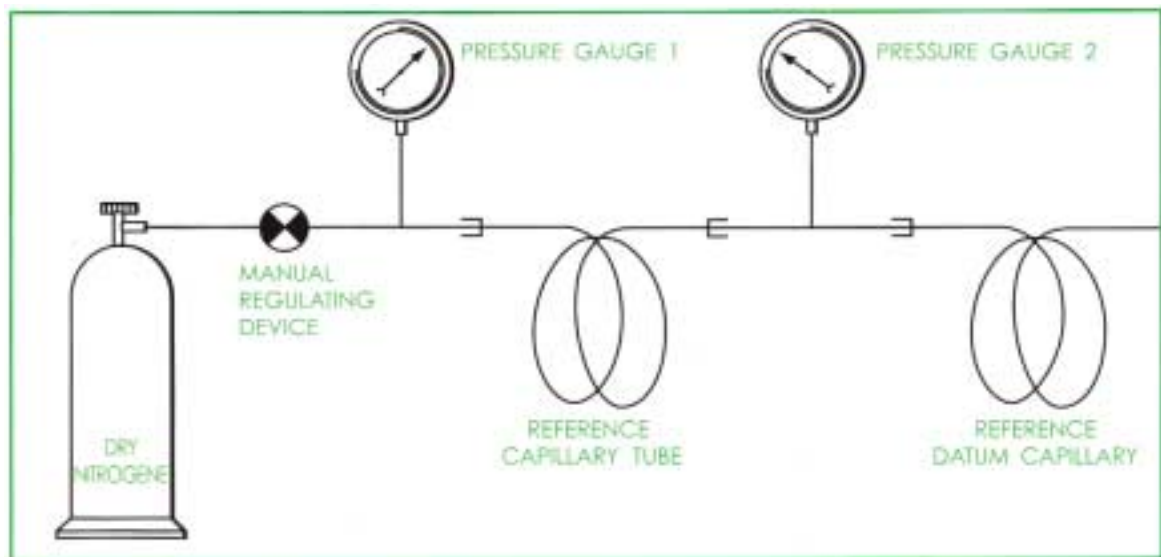

For this procedure use a cylinder of dry Nitrogen (or other source of dried and filtered compressed air) fitted with a manual pressure regulator to ensure a constant pressure of, for example, 14 bar. A capillary of the same dimensions as the one already tested in the system is fitted between pressure gauges 1 and 2. This will be used as the reference capillary.

The calibrated capillary is fitted to the outlet of pressure gauge 2. This is the reference datum capillary. Adjust the manual regulating device, take a reading of the pressures indicated.

For example: pressure gauge 1, 14 bar; pressure gauge 2, 7.8 bar.

These levels represent the reference pressure level. Maximum sensitivity is obtained with a pressure from pressure gauge 2 equal to half the reading from pressure gauge 1.

Then replace the reference tube with the capillary to be checked. Adjust the manual regulating device to read 14 bar on pressure gauge 1.

- If the tube to be checked is identical to the reference capillary, pressure gauge 2 will give a reading of 7.8 bar.
- If the pressure reading from pressure gauge 2 is above 7.8 bar, the capillary is too resistant and must therefore be shortened.
- If the pressure reading from pressure gauge 2 is lower than 7.8 bar, the capillary is not suitable for this application.

NOTE: the pressure values 14 and 7.8 bar are arbitrary and are used only as an example. It is not recommended, however, to work below 5 bar on pressure gauge 1.

4.2.5.2 LBP R404A applications

In tables listing capillary size, '2x' refers to parallel capillaries.

		CAPILLARY - INTERNAL DIAMETER							
		0.8 mm	0.036"	1 mm	0.042"	1.2 mm	0.049"	0.052"	0.054"
HG/RG2426Z				2x3m	1.5m	4m			
	2x3m			2m	3.5m				
HG/RG2432Z						3m	3.5m		
	2x2.5m	2x1.5m	2x2.5m	1.5m	2.5m				
HG/RG2436Z				2x2m	2x3m	2.5m	3m		
	2x2m		2x3m		2.2m				
HG/RG2446Z					2x2m	1.5m	1.8m	2.5m	3m
			2x2m	2x3m	1.5m	3.5m			

The grey cells refer to cabinet applications with product temperatures in the region of -20°C. The other cells are deep freeze cabinet applications with product temperatures in the region of -30°C.

4.2.5.3 MHP R404A applications

	CAPILLARY - INTERNAL DIAMETER												
	0.042"	1.2 mm	0.049"	0.050"	0.052"	0.054"	0.059" 1.5 mm	0.064"	0.069"	0.075"	2 mm	.080"	2.2 mm
HG or RG4467Z			2x2m		2x2.5m	2x3m	2x3.5	1.4m	2m	3m	3.8m		
	2x2m	1.4m	1.7m	1.80	2m	2.5m	3.5m						
HG or RG4480Z			2x1.4m		2x1.8m	2x2.m	2x2.5m	2x3.5m	1.5m	2.4m	2.8m		
		2x2m	2x3.5m	2x3.9m		1.5m	1.9m	2.6m	3.5m				
HG or RG4492Z					2x1.5m	2x1.6m	2x2.2m	2x2.9m		2m	2.3m	2.6m	3.5m
		2x2.3m	2x2.9m		2x3.6m		1.5m	2m	3.2m				
HG or RG4512Z								2x2m	2x2.9m		1.7m	1.9m	2.6m
		2x1.7m	2x2.1m	2x2.2m	2x2.5m	2x2.7m	2x3.3m	1.5m	2.1m	3.2m	3.8m		

The grey cells refer to bottle cooler cabinet applications operating at +5°C evaporation temperature and +50°C condensing temperature. The other cells refer to an application operating around -10°C evaporation temperature and +45°C condensing temperature. All MHP applications should come within these two operating envelopes.

4.2.5.4 HBP R134a applications

	CAPILLARY - INTERNAL DIAMETER							
	0.042"/ 1.067mm	1.2 mm	0.049"	0.052"	0.055"	0.049"	0.064"	0.069"
HG/RG4445Y	2x1.5m		1.5m	2.1m	2.6m	3.5m		
HG/RG4450Y		2x3m	2x3.5m	1.5m	1.8m	2.5m		
HG/RG4460Y		2x2.5m	2x3.5m		1.5m	2.m	3.m	
HG/RH4476Y		2x1.7m	2x2m	2x2.5m	2x3m	1.4m	2.m	3.m

The operating envelope is +5°C evaporation temperature +50°C condensing temperature, with 0K subcooling.

4.2.5.5 A/C R22 applications

	CAPILLARY - INTERNAL DIAMETER											
	1.0 mm	0.042"	1.2 mm	0.049"	0.052"	0.055"	0.059"/ 1.5mm	0.064"	0.069"	0.075"	2 mm	2.2mm
HG/RG5480E		2x1.8m	2x2.7m	2x3.2m		1.5m	2m	2.8m				
HG/RG5492E			2x2.3m	2x2.7m			1.7m	2.3m	3.3m			
HG/RG5510E				2x2.3m	2x2.7m			2m	2.7m			
HG/RG5512E					2x2.3m	2x2.8m			2m	3m		
RK5480E		2x1.9m	2x2.9m	2x3.4m		1.7m	2.2m	3m				
RK5490E			2x2.3m	2x2.7m			1.7m	2.3m	3.3m			
RK5510E				2x2.2m	2x2.6m			1.9m	2.6m			
RK5512E					2x2.3m	2x2.8m			2m	3m		
RK5513E					2x1.9m	2x2.3m				2.5m	3m	
RK5515E						2x1.7m	2x2.4m	2x3.2m			2.4m	3.5m
RK5518E							2x1.9m	2x2.6m			1.7m	2.8m

The operating envelope is +5°C evaporation temperature and +50°C condensing temperature, with 0K subcooling.

4.2.5.6 A/C R407C applications

	CAPILLARY - INTERNAL DIAMETER											
	1.0 mm	0.042"	1.2 mm	0.049"	0.052"	0.055"	0.059"/ 1.5mm	0.064"	0.069"	0.075"	2 mm	2.2mm
HG/RG5480C		2x1.4m	2x2.2m	2x2.6m		1.2m	1.6m	2.2m				
HG/RG5492C			2x1.8m	2x2.2m			1.4m	1.8m	2.6m			
HG/RG5510C				2x1.8m	2x2.2m			1.6m	2.2m			
HG/RG5512C					2x1.8m	2x2.2m			1.6m	2.4m		
RK5480C		2x1.5m	2x2.3m	2x2.7m		1.4m	1.8m	2.4m				
RK5490C			2x1.8m	2x2.2m			1.4m	1.8m	2.6m			
RK5510C				2x1.8m	2x2.0m			1.5m	2m			
RK5512C					2x1.8m	2x2.2m			1.6m	2.4m		
RK5513C					2x1.5m	2x1.8m				2m	2.4m	
RK5515C						2x1.4m	2x1.9m	2x2.6m			1.9m	2.8m
RK5518C							2x1.5m	2x2.0m			1.4m	2.2m

The operating envelope is +5°C evaporation temperature and +50°C condensing temperature (Mid/Mid), with 0K subcooling.

4.3 Refrigerant charge

4.3.1 Advice for installers

After pulling a vacuum in the system, break the vacuum by using the refrigerant specified on the compressor identification plate. Charge into the liquid line between the condenser and the expansion device an amount of refrigerant below that of the nominal charge so that the pressure is above atmospheric pressure. The remaining refrigerant can then be charged in vapour form into the suction line while the compressor is running. To prevent liquid refrigerant entering directly into the compressor, connect to the suction accumulator inlet if fitted and use an expansion device, either a capillary or orifice, to restrict the flow.

4.3.2 Refrigerant charge

If refrigerant migration is a problem, use the following recommended charges:

- 700 gms maximum for RG and HG compressors,
- 800 gms maximum for RK compressors.

We strongly recommend reducing charge weight as much as possible by designing a system with a low internal volume (e.g. by using high efficiency heat exchangers, low internal volume heat exchangers, short pipe runs or removing the liquid receiver when not essential...).

The refrigerant gas passes through the suction of the compressor into the compression chamber, where it is compressed and discharged into the compressor shell. This leads to a higher compressor shell temperature than in low pressure shell compressors.

When charging do not use the temperature of the compressor shell as a guideline for a full charge.

High pressure shell compressors take longer to reach normal operating pressure when starting from cold than low pressure shell compressors. This is due to the additional volume of the compressor casing and refrigerant being entrained in the oil. Condensing pressure will only reach the operating level if the entrained refrigerant evaporates completely.

4.4 Starting

Never switch on a compressor when under vacuum, an electric arc can occur inside the compressor.

4.4.1 Frequency of starts

Under no circumstances should 10-12 starts per hour be exceeded. Where this is the case an anti-short cycle or time delay relay must be fitted.

4.4.2 Start-up pressure

A maximum pressure differential of 6 bar between discharge and suction pressure is acceptable at start-up for commercial high start torque compressors.

If the pressure differential is above the recommended level due to design factors, a non-return valve in the discharge pipework near the compressor will allow the pressure differential to return to an acceptable level within 3 minutes.

This recommendation is also valid for refrigeration systems fitted with an expansion valve. Systems fitted with a capillary do not require a non-return valve as pressure equalization occurs via the capillary.

4.5 Liquid return whilst operating

POTENTIAL CAUSES	SOLUTIONS
<ul style="list-style-type: none"> • Compressor running with a dirty or partially blocked evaporator filter → 1 • Expansion valve orifice too large or stuck open → 1 - 2 • Insufficient air flow → 2 • Re-circulation of air to the evaporator → 2 • Overcharging with refrigerant → 3 - 4 	<ol style="list-style-type: none"> 1. Carry out adequate maintenance. 2. Correct installation design. 3. Check that the appropriate liquid receiver is being used. 4. Reduce the charge.

4.6 Liquid migration during prolonged shutdown

Liquid migration to the compressor can occur during transport of a factory charged system or during prolonged shutdown. The refrigerant is trapped in the compressor shell.

It can be prevented by ensuring that:

- With the compressor stopped, the temperature of the lower housing is above the ambient by 5°C,
- With the compressor running, the temperature of the lower housing is above the condensing temperature by 5°C.

See below for possible solutions.

4.6.1 Non-return valves

Non-return valves must be fitted. They can be useful when starting where a high pressure differential exists. (see § 4.4.2 Start-up pressure).

4.6.2 Pump Down

Pump Down stores liquid refrigerant in the high pressure side of the refrigeration system. In this case the use of a non-return valve is obligatory.

4.6.3 Band heaters

For the RGA and RK ranges, we recommend band heater reference number 8 583 024 listed in our Spare Parts and Accessories CD-Rom.

The band heater should be fitted onto the lower part of the compressor (above the pipe connecting the accumulator and the compressor). Plan to switch on tension only when compressor's stop.

For HGA range, we recommend our self-adhesive cartridge reference number 8 583 015, component in our Spare Parts & Accessories CD-Rom. This self-adhesive cartridge is self regulating and can be wired in permanently.

4.7 Purging refrigerant from the system

Use a refrigerant recovery unit when removing refrigerant from the system.

The flow rate should be reduced to a minimum to prevent oil in the system being entrained.

All the pressure coupling connections for controls or refrigerant recovery must allow oil to flow back into the main pipe work for return to the compressor, otherwise oil will be lost from the system.



5 Security

5.1 Pressure

Rotary compressors comply with the Pressure Equipment Directive 97/23/CE. They are classified under Class I, pressurized containers i.e. they are not required to have specific labelling with regard to the PED.

5.2 Electrical

These compressors comply with the Low Voltage Directive 73/23/CE. The applicable standards are:

- CEI335-1 [EN 60 335-1]
- CEI 335-2-34 [EN 60 335-2-34]

Most models are certified by NF, VDE, CCA, UL & CSA. Please contact Tecumseh Europe for more information.

5.3 Declaration of incorporation

The compressors are defined as for installation in machines according to the Machinery Directive 89/392/CE appendix II B, and the Pressure Equipment Directive 97/23/CE 97/23/CE. A Declaration of incorporation is available on our website at www.tecumseh-europe.com.

6 Appendices

6.1 Documents

Application Envelope High Back Pressure Commercial	26
Application Envelope Low Back Pressure Commercial	26
Application Envelope Air Conditioning	26
Anti-Vibration Piping for HGA Commercial Refrigeration Compressors	27
Anti-Vibration Piping for HGA Air Conditioning Compressors	27
Anti-Vibration Piping for RGA Air Conditioning Compressors	27
Anti-Vibration Piping for RK Air Conditioning Compressors	27

6.2 Contacts

Customer Technical Support:

Tel. +33 (0) 4 74 82 21 04

Fax: +33 (0) 4 74 82 24 89

Email: technical.support@tecumseh-europe.com

Website: <http://www.tecumseh-europe.com>

Figure 1 | Application Envelope High Back Pressure (HBP) for Rotary Compressors RG & HG

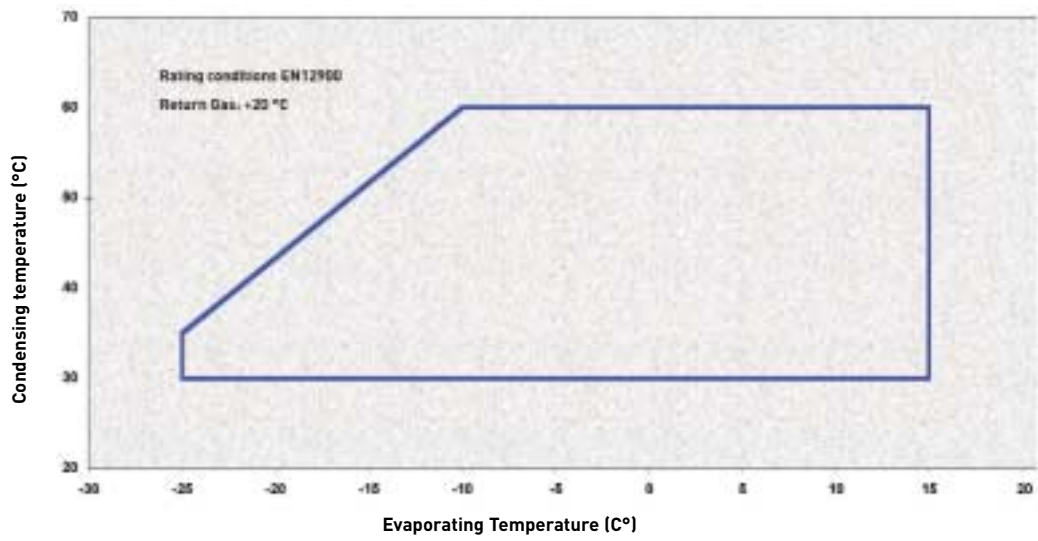

Figure 2 | Application Envelope Low Back Pressure for Rotary Compressors RG & HG

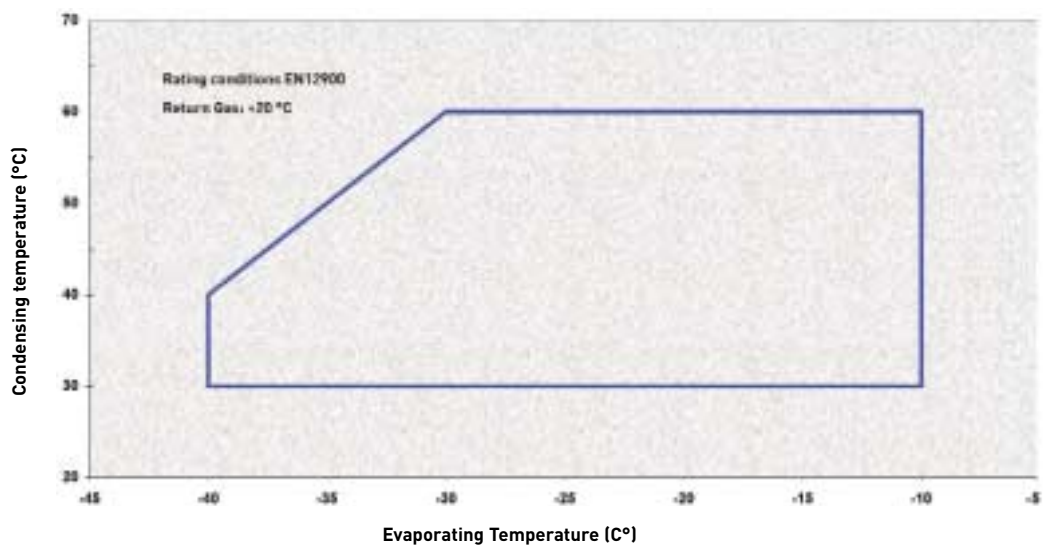

Figure 3 | Application Envelope Air Conditioning

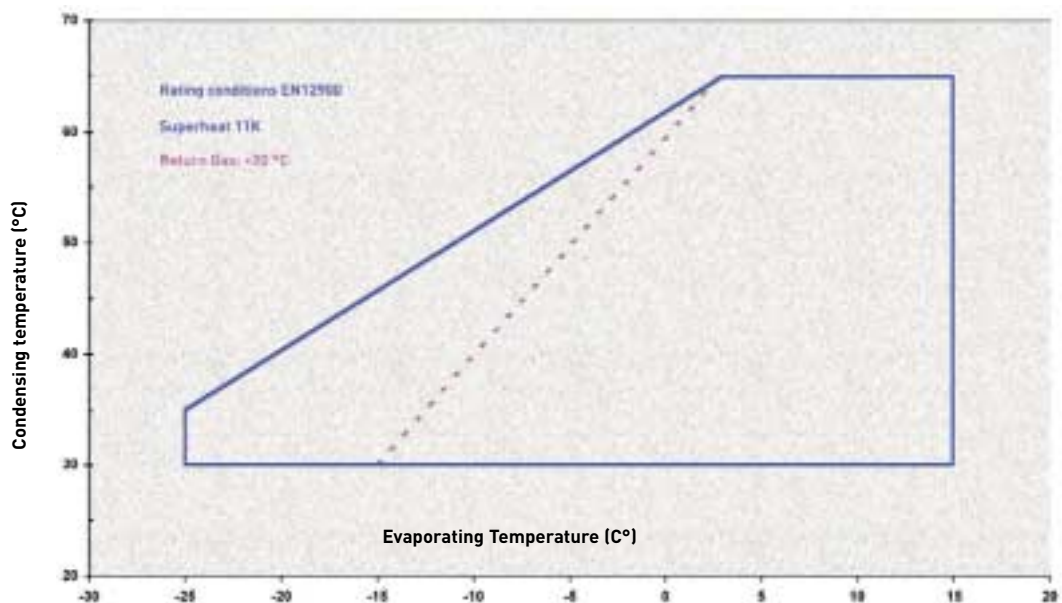

Figure 4 | Anti-Vibration Piping for HGA
Commercial Refrigeration Compressors

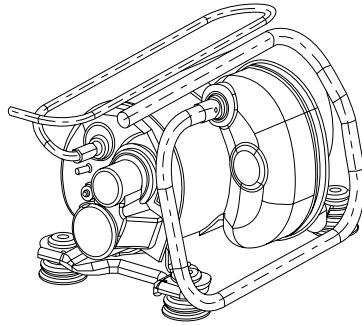

Figure 5 | Anti-Vibration Piping for HGA
Air Conditioning Compressors

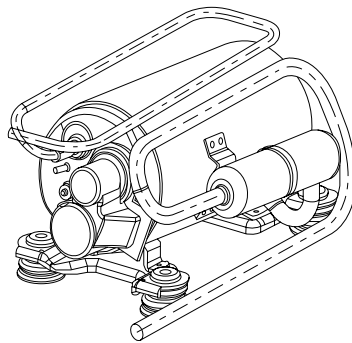

Figure 6 | Anti-Vibration Piping for RGA
Air Conditioning Compressors

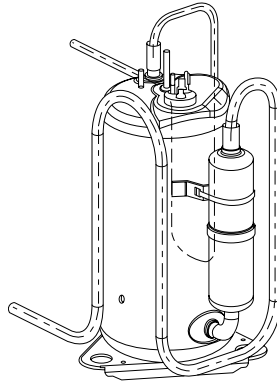
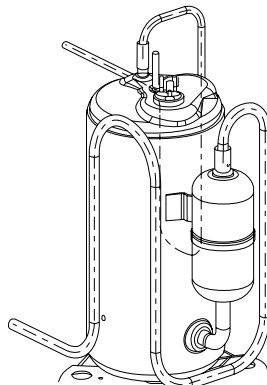

Figure 7 | Anti-Vibration Piping for RK
Air Conditioning Compressors



www.tecumseh-europe.com

